



# Application

## General Procedures for Interior and Exterior Dry Applications

### Table of Contents

<b>How to Use This Bulletin Effectively</b> .....	1
<b>Health and Safety</b> .....	1
<b>COMMON INSTRUCTIONS</b> .....	2
<b>Film and Sheeting Overview</b> .....	2
<b>Shelf Life, Storage and Shipping</b> .....	3
<b>Tools</b> .....	2
<b>Temperature</b> .....	2
<b>Substrate Preparation</b> .....	3
<b>PRE-APPLICATION INFORMATION</b> .....	3
When to Use Wet Application Methods .....	3
When to Use Dry Application Methods .....	3
Positioning the Graphic .....	3
Making Film Overlaps – Exterior Only .....	3
Registering the Graphic .....	4
Removing the Liner .....	4
Using Heat During Application .....	4
<b>APPLICATION SEQUENCES</b> .....	5
<b>Applying a Small Graphic</b> .....	5
<b>Applying a Large Graphic</b> .....	5
Top Hinge Method .....	5
Center Hinge Method .....	6
<b>Applying Diamonds, Circles, or Intricate Shapes</b> .....	7
<b>Applying Large, Prespaced Graphics</b> .....	8
<b>Applying Striping</b> .....	9
<b>Finishing</b> .....	9
Removing the Application Tape .....	9
Re-squeegeeing .....	10
Removing Air Bubbles .....	10
Cutting Around Rivets and Bolts .....	10
Slitting Substrate at Seams .....	12
Edge Sealing .....	12
<b>Irregular Surfaces and Shapes</b> .....	13
Rough, Textured and Irregular Surfaces .....	13
Complex, Compound Contours .....	13
Posts and Inside Corners .....	13
<b>Warranty and Limited Remedy</b> .....	14
<b>Related 3M Literature</b> .....	14

- To prepare the substrate prior to graphic application, see Instruction Bulletin 5.1, *Application, Substrate Selection, Preparation and Substrate-specific Application Technique*.
- If you are applying 3M Graphic Films with Comply™ Performance, use this bulletin in conjunction with Instruction Bulletin 5.31.
- Applying a graphic is more than just adhering the film to the substrate. Be sure you read and follow the instructions in all bulletins referenced in the sections you are using.

### Health and Safety

 <b>Caution</b>
<p>When handling any chemical products, read the manufacturers' container labels and the Material Safety Data Sheets (MSDS) for important health, safety and environmental information.</p> <p>To obtain MSDS sheets for 3M products:</p> <ul style="list-style-type: none"> <li>• By fax, call 1-800-364-0768 in the US and Canada or 1-650-556-8417 for all other locations.</li> <li>• Electronically, visit us at <a href="http://www.3m.com/msds">http://www.3m.com/msds</a>.</li> <li>• By mail, or in case of an emergency, call 1-800-364-3577 or 1-651-737-6501.</li> </ul> <p>When using any equipment, always follow the manufacturers' instructions for safe operation.</p>

### How to Use This Bulletin Effectively

Note: Information on how to obtain bulletins is provided in **3M Related Literature** at this end of this bulletin.

This bulletin gives you:

- General techniques for the dry application of films and sheetings with pressure-sensitive or pressure-activated adhesive to a relatively flat surface.

For the best results:

- For non-flat surfaces, complex contours, pump graphics, special applications and vehicles, see Instruction Bulletin 5.4, *Special Applications and Vehicles*.

 <b>Caution</b>
<p>Any activity performed for a long period of time in an awkward position or with a high amount of force is potentially a risk for causing musculoskeletal strain, pain or injury. When applying graphics, follow these practices to improve comfort and avoid injury:</p> <ul style="list-style-type: none"> <li>• Alternative your tasks during the application.</li> <li>• Schedule regular breaks.</li> <li>• Perform stretches or do exercises to improve circulation.</li> <li>• Avoid awkward reaching.</li> </ul>

# COMMON INSTRUCTIONS

## Film and Sheeting Overview

### 3M™ Controltac™ Plus Films

### 3M™ Controltac™ Plus Films with Comply™

#### Performance

### 3M™ Scotchlite™ Films with Comply™

#### Performance

- The pressure-activated adhesives on these films have a positionability feature.
- If part of the graphic prematurely sticks to the substrate in the wrong place, and firm pressure has not been applied, the graphic can be repositioned.
- Applying light pressure allows the film to be tacked in place for temporary positioning.
- Firm pressure to the film surface brings all the adhesive in contact with the substrate.

Note: The positionability feature of these films is lost if the film is removed from the liner and firm pressure is applied, whether you reapply the film back on its original liner, apply it to another liner, or apply it to a substrate.

- The Comply performance feature is available on selected Controltac Plus films and Scotchlite films. It allows air to move laterally through the adhesive. You can identify this feature by the texture on the liner.

### 3M Films,

### 3M™ Scotchcal™ Films and

### 3M™ Scotchlite™ Films and Sheetings

The adhesives on these films and sheetings are pressure-sensitive and adhere quickly to the substrate upon contact.

---

#### ✓ Important Note

Refer to Instruction Bulletin 5.31 for specific information on how to apply films with Comply performance, including using 3M™ Power Grip Tools.

---

## Tools

- Scotch™ Masking Tape, 1 inch or wider
- 3M™ Plastic Applicator PA-1 (Blue or Gold\*)
  - The gold applicator is most generally used. It is stiffer than the blue applicator, which allows maximum application pressure.
  - The blue applicator is used when you need more flexibility. It is softer, which allows you to mold it around contours and corrugations.

- 3M™ Low Friction Sleeve SA-1\*
- 3M™ Rivet Brush RBA-1\* and RBA-3\*
- Pin or 3M™ Air Release Tool 391X\*, or 3M™ Power Grip Multi-Pin Rivet Air Release Tool MPP-1
- 3M™ Edge Sealer \*  
(Use the one recommended for the Product Bulletin)
- 3M™ Film Cutting Tool FCT-13/32 or FCT-1/2 a hand-held rivet cutter in sizes 13/32 inch (1.0 cm) and 1/4 inch (1.3 cm); replacement tips available.\*
- Cutting tools, such as a razor blade with a safety holder
- Industrial heat gun; must be capable of attaining 500° to 750°F (260° to 399°C), or equivalent
- A 1/4 inch (0.6 mm) paint brush for applying edge sealer

\*Available from 3M Commercial Graphics Division

## Temperature and Environment

Apply graphics when the air, film and substrate temperatures are within the range specified in each film or sheeting's Product Bulletin or the Instruction Bulletin 5.35, *Applicator's Quick Reference Guide for Vehicle Graphics*. The incorrect temperature may prevent the film from performing as expected.

### Conditions that Affect Graphic Application

- Graphics applied above the maximum recommended application temperature may pre-adhere.
- Above the maximum recommended application temperature, graphics constructed of Controltac Plus films may lose their positionability feature.
- The temperature of the substrate must be above the dew point to prevent moisture from condensing on the surface.
- In very humid conditions, it may be difficult to keep the substrate dry.
- Below the minimum recommended application temperatures, films and sheetings become stiff and brittle. The adhesive cannot bond adequately with the substrate. In addition, 3M™ Controltac™ Plus Films can trap air and cause bubbling.
- Substrates may be heated in order to raise the surface temperature above the minimum specified. Use an appropriate portable heater or heat lamps.

## Substrate Preparation

See Instruction Bulletin 5.1 for details on cleaning specific substrates and special, required application techniques.

- If the substrate has dirt or loose paint on it, that is what the film adheres to—not the substrate itself. If the film does not make enough contact with a clean dry substrate, it will not stick well, leading to premature graphic failure.
- The final cleaning of the substrate must be done immediately before applying film. Dust and other contaminants can collect quickly on the substrate and prevent the film from adhering properly.
- Be sure the substrate, rivets and seams are thoroughly dry. Film adheres poorly even to a properly cleaned substrate if there is any remaining liquid around the rivets and seams.

## Shelf Life, Storage and Shipping

- Unprocessed film has a shelf life of 2 years after receipt from 3M. Processed film has a shelf life of 1 year. However, the total shelf life of a graphic before and after processing cannot exceed 2 years.
- Store the film in the original container.
- Store the film in a clean dry area, out of direct sunlight and at less than 100°F (38°C) and 80% relative humidity.
- Ship the finished graphic lying flat or roll the graphic. To roll the graphic, wrap it image-side out onto a core that is 6 inches (15 cm) or larger in diameter. These methods help prevent the liner and application tape from wrinkling or popping off.

# PRE-APPLICATION INFORMATION

### General

- Replace the plastic applicator if the edges become nicked or ragged. Damaged edges leave bubbles and scratch the graphic.
- If the graphic does not have an application tape, use a low friction sleeve on the applicator to minimize scratching the graphic.
- A smooth substrate is the most ideal application surface. However, many surfaces that appear smooth may actually be irregular or uneven, such as a speckled or textured plaster surface. These surfaces are generally used for interior walls but may be found elsewhere.

### When to Use Wet Application Methods

Only use an application liquid such as detergent and water if that method is *specifically recommended* in the film's Product Bulletin.

### When to Use Dry Application Methods

Any liquid remaining under the graphic prevents it from adhering properly. Certain substrates are very difficult to dry. We recommend only dry application for the following situations:

- Graphics made with 3M™ Controltac™ Plus Films, 3M™ Scotchlite™ Plus Films and Sheetings and 3M™ Scotchlite™ Films and Sheetings.
- 3M Graphic Films with the 3M™ Comply™ Performance feature.
- 3M™ Scotchcal™ Perforated Window Graphic Film with an overlamine.
- Vehicles.
- Uneven and non-flat application surfaces.
- Graphics subjected to freezing conditions within several days of application.

### Graphic Placement

Proper placement of the graphic can make the job easier. To minimize application problems, follow these guidelines for positioning the graphic.

Note: If you lay the graphic on the floor, it will pick up dirt on the back and transfer it to your clean substrate.

- Test your layout by temporarily positioning the graphic on the substrate. Use masking tape to hold it in place. This ensures that the graphic will fit and all the pieces are available.
- Position the graphic to minimize the number of rivets and substrate seams that will be covered. Moving the graphic just 1 to 2 inches (2.5 to 5 cm) may avoid a row of rivets.
- If there are rivets, position the graphic so the film extends at least 1/2 inch (1.3 cm) past the rivet and covers as many rivets as possible. This eliminates the need to cut around the rivets.
- Do not allow the edge of a graphic to fall on rivets.
- If the film covers seams in the substrate, you will need to cut through the film as described in **Substrate Seams** on page 12.
- Grasping the edge of the film may transfer body oils and dirt to the adhesive. To minimize any problems with adhesion at those points, grasp the film as far into graphic as possible without wrinkling the film.

### Making Film Overlaps - Exterior Only

Environmental conditions such as wind, rain, and blowing debris stress the overlapped edges of graphics. Use careful planning for both vertical and horizontal film overlaps to reduce the stress and damage.

Note: Overlaps greater than 1/2 inch (13 mm) may contribute to edge lifting.

### Vertical Film Overlaps

Any overlaps on films applied vertically must face away from the front of the vehicle. Apply the first piece of film at the rear of the vehicle. Work to the front, overlapping each additional piece by 1/4 to 1/2 inch (6 to 13 mm), but no more than that. Repeat for the other side, again starting from the back.

### Horizontal Film Overlaps

Apply the lower piece of film first. Work toward the top, overlapping each subsequent piece by 1/4 to 1/2 inch (6 to 13 mm), but no more than that.

### Registering the Graphic

Mark on the substrate the exact location of the top and sides of the graphic with masking tape, a lead pencil, or marking pen. Do not use a chalk line, china marker or grease pencil, which will contaminate the adhesive and cause edge failure.

### Removing the Adhesive's Liner

1. Lay the graphic liner side up against a flat, clean surface.
2. Flick a corner of the film with your finger or bend the corner to separate the liner from the adhesive. If the liner is scored, bend at the score.
3. Remove only as much liner as required for your application method. As you're removing the liner, keep your fingers away from the edge of the adhesive as much as possible. Contamination on the adhesive edges may cause the edges of the film to lift after application. See Figure 1.

The procedure for removing the liner, whether just a small part of it or the entire liner is to pull it away from the graphic at a 180 degree angle with a smooth continuous motion. See Figure 1.

Note: Always remove the liner from the graphic rather than the graphic from the liner. This method:

- Helps ensure that the tape removes any pre-spaced graphics from the liner.
- It minimizes stretching or wrinkling of the graphic

### Using Heat During Application

Heat is required during some application steps. Most films withstand a moderate amount of heat. However, films designated "e-film" are more sensitive and can dull or curl if too much heat is used.

### Caution

Heat or open flames may contribute to a flash fire or burns. Follow these precautions when using a heat source for flame treating.

- Read and follow the instructions supplied with the heat source.
- Avoid personal contact with the heat source. Wear heat-resistant gloves and safety glasses.
- Do not use heat sources near solvent mixtures or residues, or where solvent vapors may be present.

### Caution

Always provide adequate ventilation to remove emissions that result from the heat of flame treating. Failure to provide adequate ventilation can result in operator exposure.

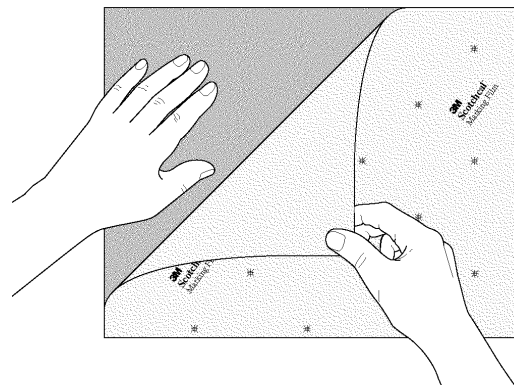

CG-250A

Figure 1. Pulling Off A Liner

# APPLICATION SEQUENCES

## Applying a Small Graphic

A graphic is considered small if:

- It has positionable adhesive and is less than 9 square feet (0.8 m<sup>2</sup>).
- It has pressure-sensitive adhesive and is less than 4 square feet (0.4 m<sup>2</sup>).

1. Remove the entire liner.
2. Use your thumb to gently tack the top edge of the graphic in place. See Figure 2.

3. Use firm pressure on the plastic applicator and overlapping strokes. If possible, start in the center of the graphic. Always squeegee the shortest distance to the edge of the graphic. Hold the remaining film away from the surface. See Figure 3.

Note: Pull the squeegee, as shown in Figure 3, rather than pushing it. Pushing can stretch the graphic.

4. Pull the film away where you tacked it with your thumb and then squeegee that area; this prevents wrinkles. See Figure 4.
5. To complete the application, go to **Finishing**, on page 9.

## Applying a Large Graphic

A graphic is considered large if:

- It has positionable adhesive and is larger than 9 square feet (0.8 m<sup>2</sup>).
- It has pressure-sensitive adhesive and is larger than 4 square feet (0.4 m<sup>2</sup>).

### Top Hinge Method

1. Position the graphic, using strips of Scotch™ Masking Tape to hold the graphic to the substrate. Then, apply a strip of masking tape 2 to 3 inch (5.1 to 7.5 cm) wide, horizontally across the top of the graphic. See Figure 5.

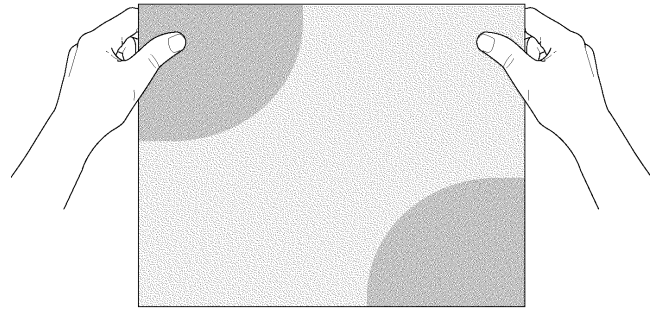

CG-252A

Figure 2. Tack One Edge of the Graphic

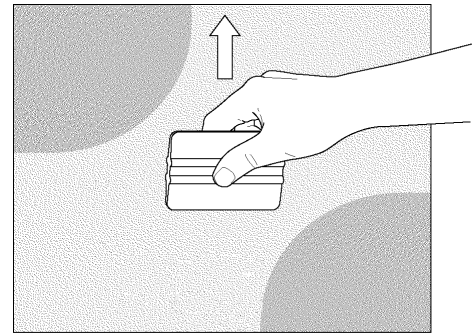

CG-253A

Figure 3. Squeegee Across the Shortest Distance

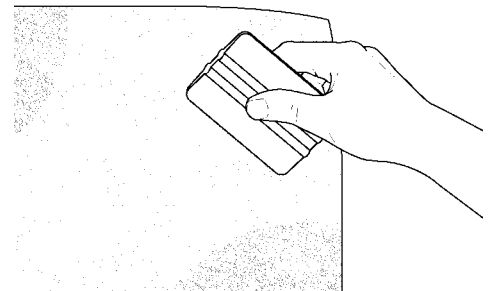

CG-254A

Figure 4. Squeegee the Area That Was Previously Only Tacked

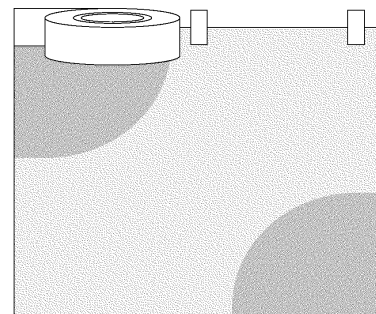

CG-255A

Figure 5. Make a Top Hinge

2. Raise the graphic up over the top of the hinge and peel the liner back a few inches. See Figure 6.

Note: The entire liner may be removed at this time, if desired. However, for very large graphics, especially those with a pressure-sensitive adhesive, leaving the liner in place just prior to squeegeeing makes the graphic more controllable, keeps the adhesive clean, and reduces the possibility of stretching the film.

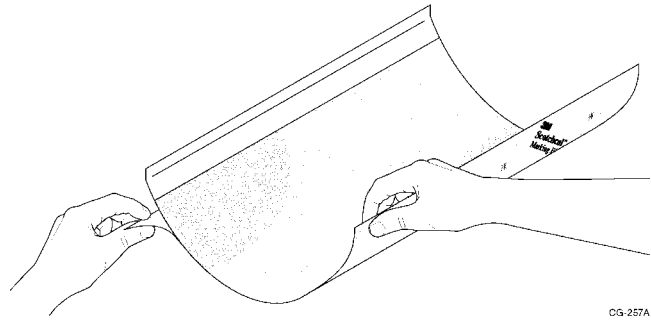

Figure 6. Lift the Graphic and Peel Back the Liner

3. Begin squeegeeing at the top center. Squeegee the graphic beginning at the center of the tape hinge and working outward from the hinge to the closest edge. Use firm pressure on the plastic applicator and overlapping strokes. See Figure 7.

4. Hold the graphic away from the surface and gradually remove the liner while squeegeeing down to the end.

Note: Pull the squeegee, as shown in Figure 7, rather than pushing it. Pushing can stretch the graphic.

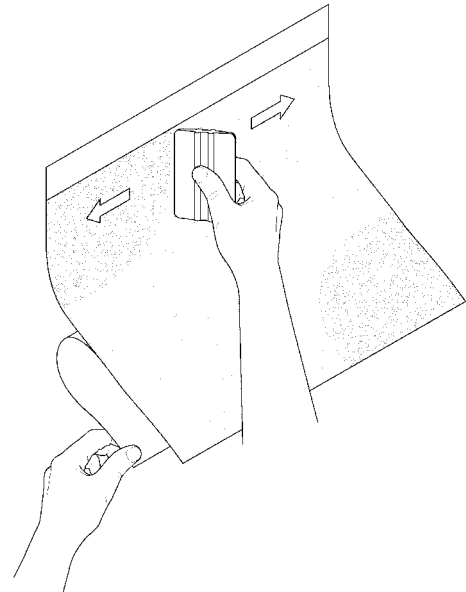

Figure 7. Squeegee a Top Hinged Graphic

5. Remove the tape hinge. Squeegee the top edge.
6. To complete the application, go to **Finishing**, on page 9.

### Center Hinge Method

1. A center hinge can be either vertical or horizontal, whichever is the shortest distance.
2. Position the graphic and hold it in place with 1 or 2 inch (2.5 to 5 cm) wide strips of masking tape.
3. Apply two layers of masking tape, 1 or 2 inch (2.5 to 5 cm) wide, through the center of the graphic to make a hinge. The hinge should be perpendicular (at right angles) to the longest distance. See Figure 8.

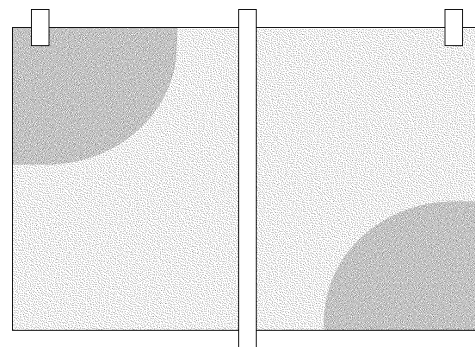
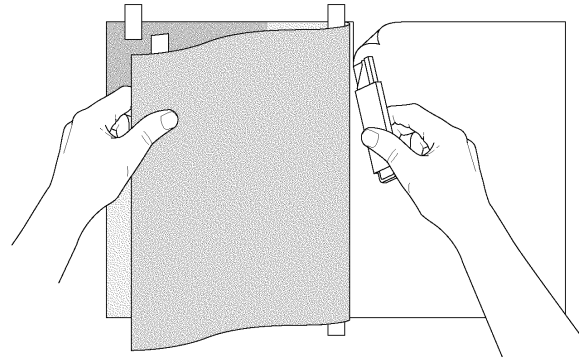

Figure 8. Make a Center Hinge

4. Fold half of the graphic back over the hinge. Peel off the liner all the way to the tape hinge. Then cut just the liner along the hinge. Discard the liner. See Figure 9.
5. Fold the graphic back onto the substrate.



CG-260A

**Figure 9. Remove Liner on a Center Hinged Graphic**

6. Hold the graphic away from the surface with one hand. Allow the adhesive to touch the substrate as pressure is applied during squeegeeing. Squeegee the graphic beginning at the center of the tape hinge and working outward to the closest edge. See Figure 10. Use firm pressure on the plastic applicator and overlap the strokes.
7. Remove the tape.
8. Apply the other half of the graphic in the same manner.
9. To complete the application, go to **Finishing**, on page 9.

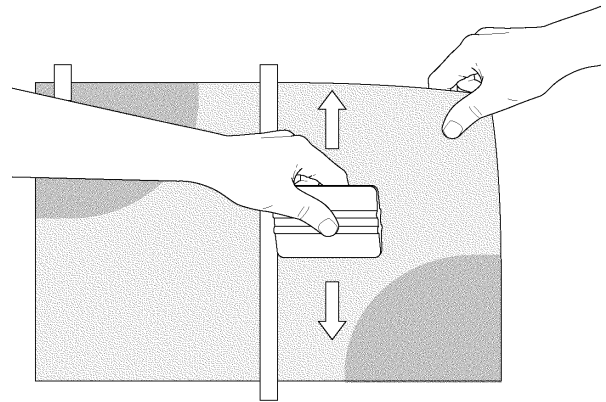

CG-261A

**Figure 10. Squeegee a Center Hinged Graphic**

## Applying Diamonds, Circles, or Intricate Shapes

1. Use the **Center Hinge Method**, page 7. Apply a tape hinge across the graphic approximately 1/3 of the distance from the edge. See Figure 11.

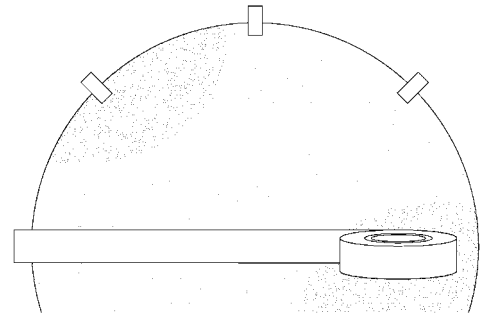

CG-265A

**Figure 11. Make a Center Hinge on an Intricately-Shaped Graphic**

2. Again, following the techniques in **Center Hinge Method**, squeegee the graphic beginning at the center of the tape hinge and working outward to the closest edge. See Figure 12.

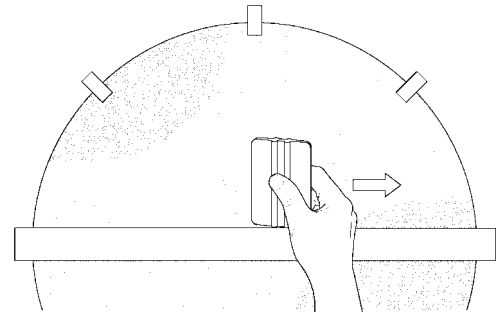

CG-266A

**Figure 12. Squeegee an Intricately-Shaped Graphic**

## Applying Large, Prespaced Graphics

Prespaced graphics have cut areas with large amounts of the liner exposed. Prespaced graphics should have an application tape already applied.

Note: If the application tape does not remove all of the prespaced graphics easily from the liner, press the elements back onto the liner. Then gently pull the graphic liner-side down over the corner edge of a surface. See Figure 13.

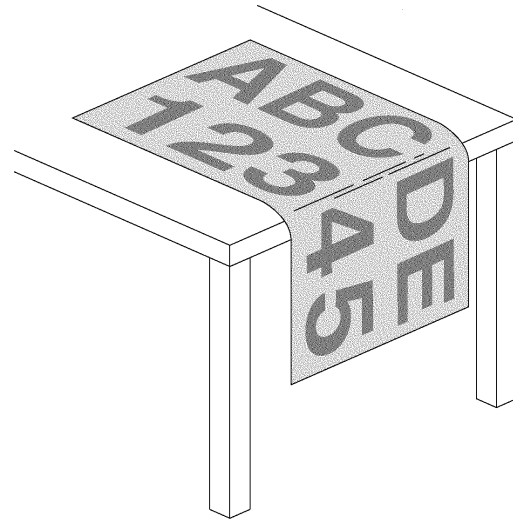

CG-251A

Figure 13. Loosening Prespaced Graphics From A Liner

1. Apply a hinge. See **Top Hinge Method** on page 5 and Figure 14.

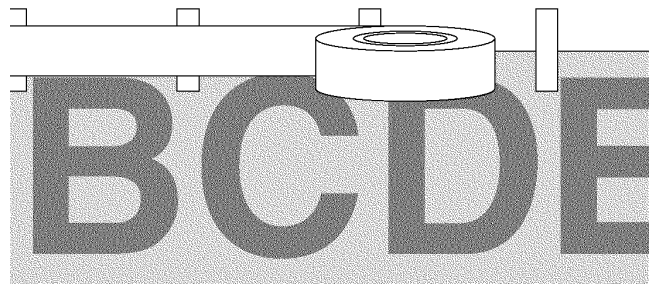

CG-267A

Figure 14. Make a Top Hinge on Prespaced Graphics

2. Cut between each element, starting just above the top edge of the film, which is partially covered by tape. This makes an independent hinge for each element. See Figure 15. To avoid cutting the substrate, lift the graphic away from the substrate cut only the film.
3. Remove the liner and squeegee each element in place. Use firm pressure and overlapping strokes. Always squeegee the shortest distance to the edge of each individual element.

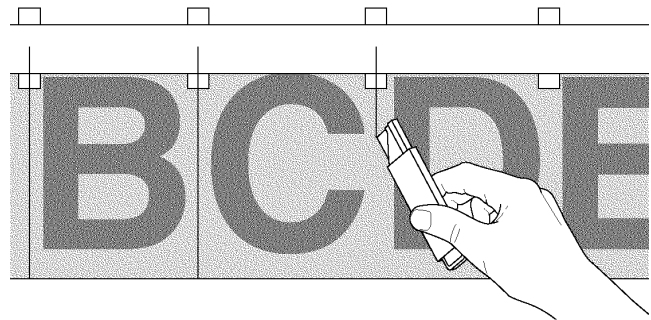

CG-268A

Figure 15. Cut Between the Elements of a Prespaced Graphic

Note: Squeegee over all areas of the prespaced graphics and application tape, not just the individual elements.

## Applying Striping

The preferred method for striping is to apply it so that it ends just before the edge of the substrate. An alternate method is to wrap the striping around the edge, such as on a door. However, this method subjects the film or sheeting to more abrasion. Both methods are described here.

1. Use the **Center Hinge Method**, page 7. Make the hinge perpendicular to the long dimension of the stripe. See Figure 16.

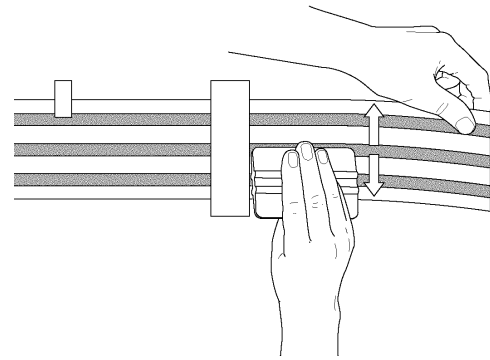

CG-269A

Figure 16. Make a Center Hinge for Striping

2. If the film/sheeting *will not* be wrapped around an edge, apply the stripe to within 1/4 inch (6 mm) of the substrate edge. See Figure 17.

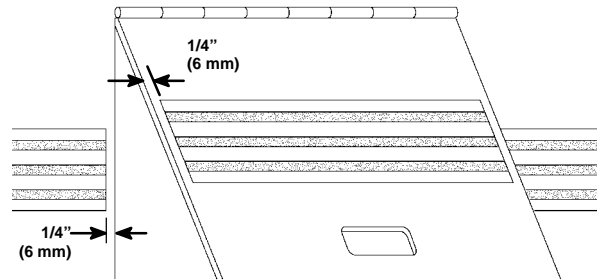

CG-270A

Figure 17. Applying Striping Without Wrapping

3. If the film/sheeting *will be* wrapped around an edge:
  - a. Make sure the inside surface is clean.
  - b. Extend striping 1 inch (2.5 cm) or more beyond the edge.
  - c. Wrap firmly and squeegee the film to the back of the substrate. Avoid trapping air in this area. See Figure 18.

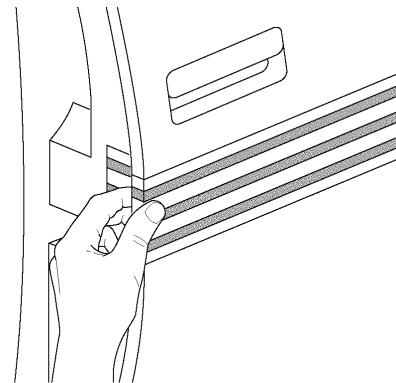

CG-271A

Figure 18. Applying Striping With a Wrap

## Finishing

Note: Use a low friction sleeve on the squeegee if the graphic does not have an application tape or if the tape has been removed.

### Removing the Application Tape

Note: Before removing the application tape, read about **Rivets**, later in this section.

Application tape should not be left on the graphic. Prolonged exposure to sunlight will permanently adhere it to the graphic.

Remove the application tape from the graphic by pulling it back upon itself at a 180 degree angle. See Figure 19. It is acceptable to tear the premask into manageable sized pieces.

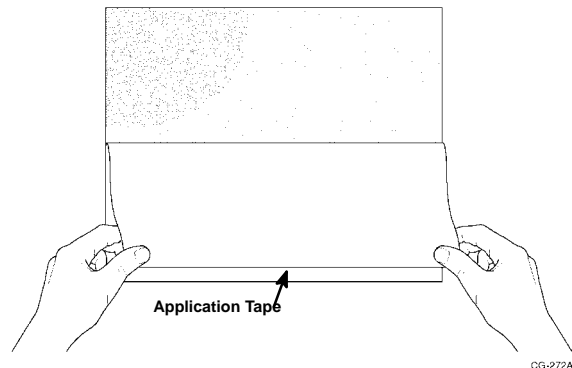

CG-272A

Figure 19. Removing Application Tape

## Re-squeegeeing

### ✓ Important Note

ALWAYS re-squeegee after removing application tape, because removal may loosen the edges of the graphic. This is a critical step for all graphics, but especially if the film is thick or has pressure-activated adhesive. Loose edges may lift and can be damaged.

1. Use firm pressure to re-squeegee all rivets, graphic edges, substrate seams and film overlaps.
2. Give special consideration to graphics applied near the minimum application temperature.

Graphics may not develop ultimate adhesion if they are applied near the minimum application temperature and then put immediately into service in winter weather.

To improve adhesion, which reduces edge lifting, use a gun along the rivets, film edges, substrate seams and overlaps when re-squeegeeing.

### Removing Air Bubbles

1. Inspect the graphic for bubbles.
2. Puncture the bubble at one end with a pin or the 3M™ Air Release Tool 391X. Do NOT use a razor blade or knife.
3. Press out the entrapped air by moving your thumb toward the puncture. See Figure 20.

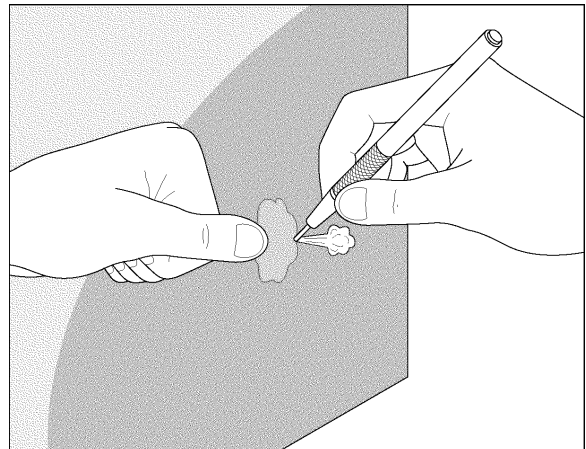

CG-273A

Figure 20. Puncturing and Rubbing Out a Bubble

### Cutting Around Rivets and Bolts

Applying film over raised areas such as rivets or bolts causes low to moderate tenting over the area, which traps air that must be removed.

#### *Air Release Tool for Rivets*

1. Before removing the application tape, use a pin or the 3M™ Air Release Tool 391X to puncture several holes in the graphic. Or, use a 3M™ Power Grip Multi-Pin Rivet Air Release Tool MPP-1, which requires only one stroke to puncture several holes. Do NOT use a knife or razor blade. See Figure 21.

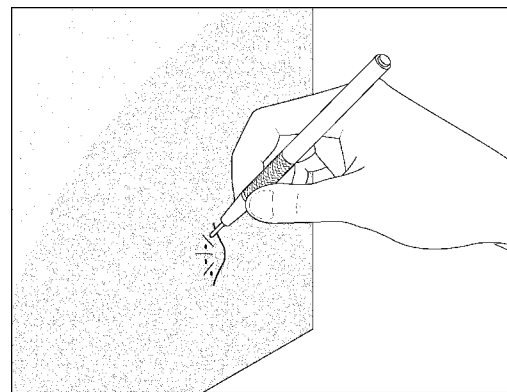

CG-274A

Figure 21. Puncturing Air Release Holes Around Rivets

2. Push as much entrapped air as possible toward the punctures using a rivet brush or plastic applicator.
3. Remove the application tape at a 180 degree angle. Refer to Figure 19, page 9.
4. Heat the film with a heat source held several inches away from the graphic and re-brush around the rivet. See Figure 22.

Note: Overheating the film scorches it. Excessive heat softens the film too much and causes it to wrinkle. Heat softens the films so it will conform. Without sufficient heat, the film will tent later.

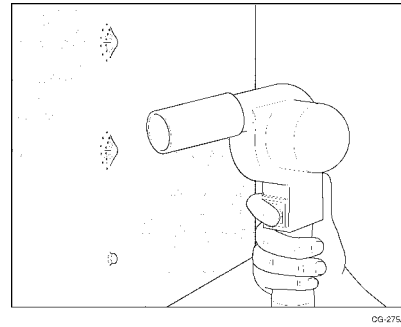

**Figure 22. Heating Film Around Rivets**

#### ***How to Use a Rivet Brush***

1. Start a circular brushing motion around the outer edges of the air release holes. See Figure 23, A.
2. Continue brushing as you narrow the circle to the area immediately over the rivet. This conforms the film to the rivet. See Figure 23, B.

#### ***Cutting Around Rivets***

Some films and substrates require that the rivets be cut around. If the graphic is not cut, some lifting occurs and the graphic may crack and come loose later.

1. Use a 3M™ Film Cutting Tool around rivets under the following circumstances. See Figure 24.
  - Stainless steel substrates.
  - Film does not extend 0.5 inch (1.3 cm) or more beyond the rivet edge.
  - Rivets that are excessively high.
  - Reverse rivets, where the rivet head is on the inside and the film goes over the exposed shank end.
  - 3M™ Scotchlite™ Diamond Grade™ Sheeting.
  - If the base film (not including an overlamine) is greater than 2 mil (0.05 mm) thick and it *is not* a Scotchlite sheeting (except diamond grade sheeting), and:
    - the appearance of tented film over the rivets is objectionable, and/or
    - long-term, outdoor applications, and/or
    - applications where closely spaced rivets are closer than:
 

Single row	1.5 inches (3.8 cm)
Double row	3 inches (7.7 cm)
2. Remove the circles of film from the tops of the rivets, if desired.
3. Brush the film down in a circular motion with the rivet brush. See Figure 23.

**A. Start brushing in a larger circle**

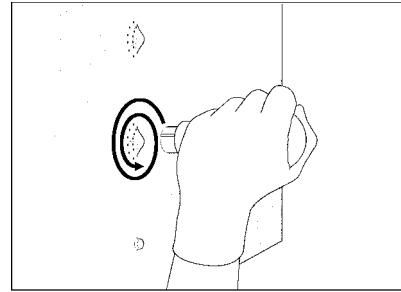

**B. Finish brushing in a small circle**

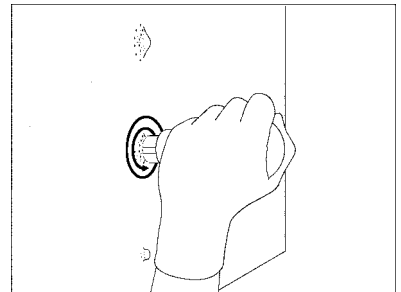

**Figure 23. Conforming Film Around Rivets with a Brush**

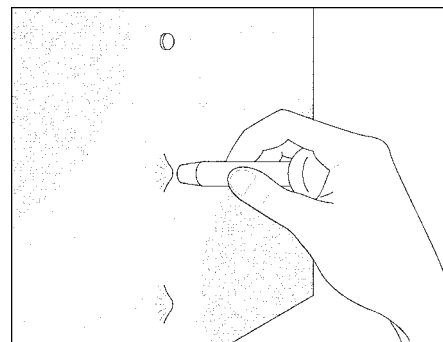

**Figure 24. Cutting Around Rivets**

### **Bolts**

1. Apply the graphic over the bolt just like you would over a rivet.
2. Cut an **X** through the film directly over the bolt. See Figure 25.
3. Brush the film down with the rivet brush held at a 45 degree angle.
4. Carefully cut the film around the bolt at a 90 degree angle or with a film cutting tool.

### **Slitting Substrate at Seams**

Seams in the substrate, whether or not they are caulked or filled, can retain moisture. They are also the point at which the substrate will flex under certain conditions. To ensure the film does not lift or tear at the seams, the graphic **MUST** be slit at the seam.

### **All Substrate Seams**

Slit the graphic along the entire length of all substrate seams. Use a sharp razor blade in a safety holder. See Figure 26.

### **Seams with Caulking or Gaskets**

1. Films that bridge over a caulked seam or gasket will not adhere. If the edges are not cut, moisture can get behind the graphic and cause it to fail. Cut the film on both sides of the caulking and remove the strip of film covering the caulking or gasket. See Figure 27.
2. Re-squeegee all seam edges with a plastic applicator or rivet brush.

### **Edge Sealing**

 <b>Caution</b>
Before handling any chemical products, always read the container label and the MSDS.

The following applications do not require edge sealing, but it may help keep the edges from lifting when subjected to external sources such as abrasion and/or high-pressure washing.

- Railroad rolling stock and locomotives
- Exposure to high-pressure wash
- Exposure to severe abrasion
- Chrome
- Truck roll-up doors

Note: If you use high pressure to wash a graphic, even if the edges are sealed, the warranty may be voided if you exceed the pressure washing recommendations in Instruction Bulletin 6.5.

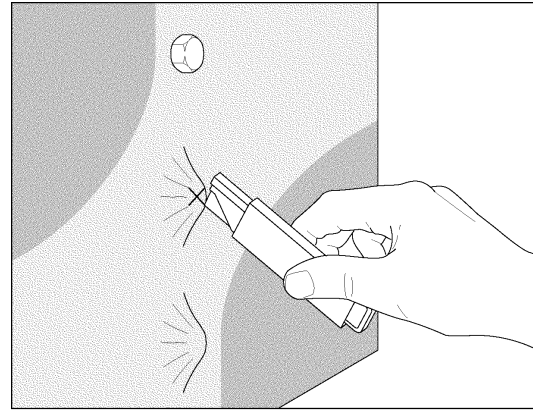

CG-278A

**Figure 25. Cutting Around Bolts**

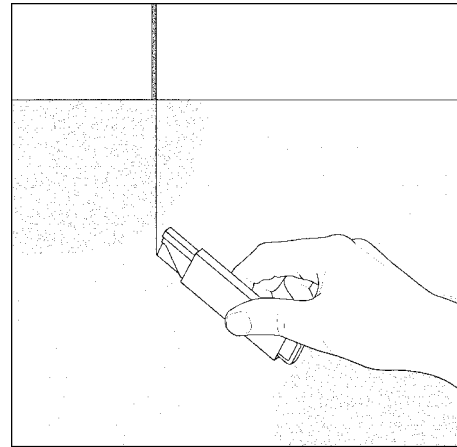

CG-279A

**Figure 26. Cutting at an Overlapped Substrate Seam**

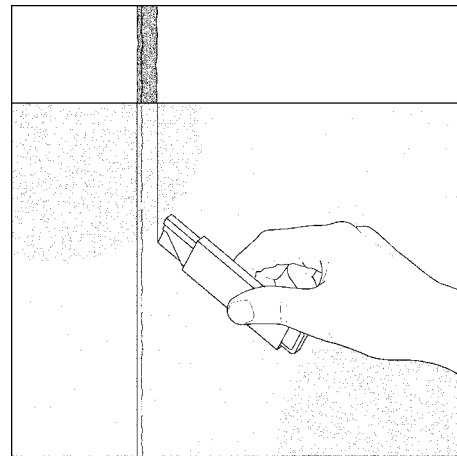

CG-280A

**Figure 27. Cutting at a Caulked or Gasketed Substrate Seam**

### Edge Sealing for Sheetings

Edge sealing is required when sheeting is used in fuel spill areas.

### Types of Edge Sealer

When in doubt, check the film Product Bulletin for the appropriate edge sealer. These are general guidelines.

Type of 3M Films	3M™ Edge Sealer	Minimum Temperature
Vinyl films	3950	None
E-film	None	None
Polyester films	Overprint clear 900	None
Reflective sheeting	4433	55°F(13°C)
Diamond grade sheeting	Toner 880	50°F(10°C)

### How To Apply Edge Sealer

1. Do not apply edge sealer unless the temperature is above the minimum recommended temperature.
2. Remove the application tape and re-squeegee the edges before applying the edge sealer.
3. Use the felt dauber supplied with edge sealer or a 1/4 inch (0.6 cm) brush.
4. Wipe any excess edge sealer off the dauber or brush.
5. Hold the brush or the flat edge of the dauber so that it straddles the film and substrate
6. Pull the dauber or brush along the edge in a smooth, continuous motion. Make sure the entire edge is covered with no gaps. See Figure 28.

### Storing Edge Sealer 4433

- Edge sealer 4433 is a two-part system. It must be used immediately after mixing.
- Tightly seal the cap of the edge sealer container.
- Store in a cool, dry place.
- Use within 1 year of purchase.

## Irregular Surfaces and Shapes

### Rough, Textured and Irregular Surfaces

Use a rivet brush to conform the film to these surfaces.

### Complex, Compound Contours

Refer to Instruction Bulletin 5.4, *Special Applications and Vehicles*.

### Posts and Inside Corners

1. Use the desired hinge method as described earlier in this bulletin. Make the hinge parallel to the post.
2. For exterior applications only, all film applied to inside (concave) corners must be cut. See Figure 29.
3. After cutting and removing the application tape re-squeegee or use a rivet brush to make sure that film is securely applied.

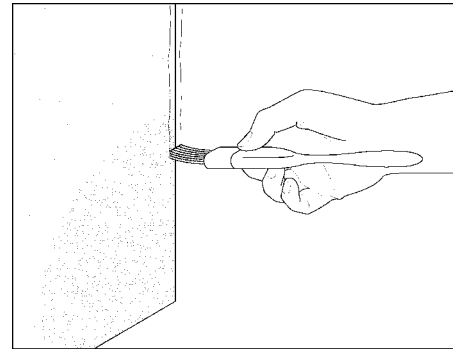

Figure 28. Applying Edge Sealer

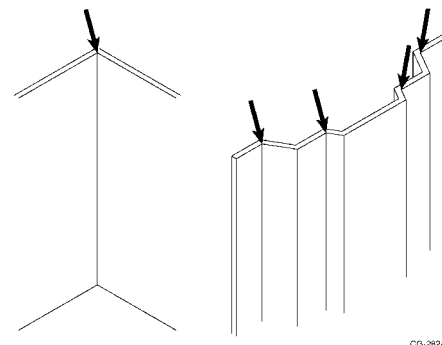

Figure 29. Posts and Inside Corners

## Warranty and Limited Remedy

The information contained and techniques described herein are believed to be reliable, but 3M makes no warranties, express or implied, including but not limited to any implied warranty of merchantability or fitness for a particular purpose. 3M shall not be liable for any loss or damages, whether direct, indirect, special, incidental or consequential, in any way related to the techniques or information described herein.

### 3M Related Literature

Listed below is related 3M technical literature that may be of interest. You may view and print these Bulletins from our Web site at [www.scotchprint.com](http://www.scotchprint.com), or order them via our Fax-on-Demand (FOD) system. Call one of these phone numbers to order the desired bulletins, and specify the FOD document number provided in the chart.

United States or Canada: 1-800-364-0768  
International: 1-651-732-6506

Subject	Bulletin No.	FOD No.
<b>Product Bulletins</b>		
Film or Sheeting	Same as film or sheeting	Call FOD
<b>Instruction Bulletins</b>		
Application: Substrate Selection, Preparation and Substrate-specific Application Techniques	5.1	7001
Application, Special Applications and Vehicles	5.4	7004
Applying 3M Graphic Films with Comply™ Performance	5.31	7031
Cutting and Applying Curtain Sided Vehicle Film	5.12	7012
Application, 3M™ Scotchlite™ Diamond Grade™ Conspicuity Sheeting Series 981	5.13	7013
Applicator's Quick Reference Guide for Vehicle Film	5.35	7035
Application of Auto Graphics	5.36	7036
Storage, Handling, Maintenance, Removal	6.5	8505

Subject	Bulletin No.	FOD No.
<b>Warranties</b>		
<b>Worldwide 3M™ MCS™ Warranty Packet</b> <i>(includes all Commercial Graphics MCS Warranties)</i>		9503
Worldwide 3M™ MCS™ Warranty Overview-Folder		9504
Scotchprint® Graphics Warranty <i>(includes overview)</i>		9505
3M™ MCS™ Graphics Warranty for Fleet Vehicle Applications <i>(includes overview)</i>		9506
3M™ MCS™ Graphics Warranty for 3M™ Panaflex™ Awning and Sign Facings <i>(includes overview)</i>		9507
3M™ FloorMinders Graphics Warranty <i>(includes overview)</i>		9508
Auto Graphics Warranty		9509
3M Bus Graphics Policy and Warranty Statement	75-5100-1315-6	



#### Commercial Graphics Division

3M Center, Building 220-6W-06  
PO Box 33220  
St. Paul, MN 55133-3220 USA  
General Info. 1-800-374-6772  
Technical Info. 1-800-328-3908  
Fax 1-651-736-4233

Fax-on-Demand 1-800-364-0768 US/Canada or 1-651-732-6506 International  
Fax-on-Demand document: 7005

[www.scotchprint.com](http://www.scotchprint.com)

#### 3M Canada

P.O. Box 5757  
London, Ontario  
Canada N6A 4T1  
1-800-265-1840  
Fax 519-452-6245

#### 3M México, S.A. de C.V.

Av. Santa Fe No. 55  
Col. Santa Fe, Del. Alvaro Obregón  
México, D.F. 01210  
52-55-52-70-04-00  
Fax 52-55-52-70-22-77

#### 3M Puerto Rico, Inc.

Puerto Rico Industrial Park  
P.O. Box 100  
Carolina, PR 00986-0100  
787-620-3000  
Fax 787-750-3035

©3M 2002. All rights reserved.